

(6) Thrust Angular Contact Ball Bearings for Ball Screw

1) Features

This is highly rigid and accurate ball screw support bearing often used for the machine tools driving mechanism.

(a) High axial rigidity

High-rigidity achieved by higher contact angle at 60 degrees and an increased number of smaller-diameter balls.

(b) Small friction torque

Friction torque is far less than that of tapered or cylindrical roller bearing. This contributes to accurate rotation by a smaller driving power.

(c) Pre-adjusted axial play

Combination bearings are already adjusted to a suitable preload. Universal combination bearing (SU) furnishes certain preload for all combinations (DB, DF, and other).

(d) Simple mounting structure

A duplex combination of bearings can receive axial and radial loads. Therefore, the installation structure is simpler than when both a thrust bearing and a radial bearing are used.

(e) Easy handling

Inner and outer rings are inseparable, and are easy to handle.

(f) Superb polyamide resin retainer

Uses polyamide resin retainer which is superb to friction and furnishes high precision rotations.

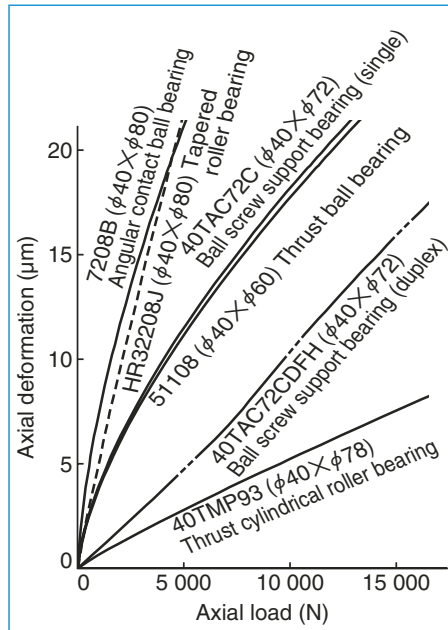

Fig. 1 Axial rigidity of various bearings

Table 2 Comparison with other types of bearings

Bearing type	Bearing rigidity (See Fig. 1)	Starting torque	Preload adjustment	Installation structure
Thrust angular contact ball bearing for NSK precision ball screw support unit	High	Low	Not required	Simple
Combined angular contact ball bearing	Low	Low	Not required	Simple
Tapered roller bearing	Low	High	Complicated	Simple
Thrust ball bearing and radial bearing	High	Low	Complicated	Complicated
Thrust cylindrical roller bearing and radial bearing	Extremely high	Extremely high	Complicated	Complicated

Note: Consult NSK when you use these bearings other than the purpose of ball screw support.

2) Composition of reference number

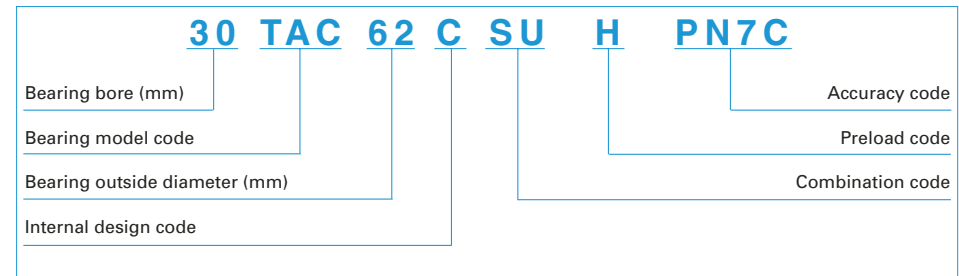

Note: As "30 TAC 62 C," any part of the first half of the reference number is referred to as "nominal size" in this catalog.

3) Combinations of bearings

Generally, a set uses more than two pieces (referred to as 'two rows') of bearings and, thus the preload is applied.

There are two types of combination:

● Combined bearings

Bearings are adjusted as a single combined set. Since the bearing alignment is pre-set, there is no interchangeability between the bearing set.

● Universal combination bearing (SU)

Single bearings are manufactured under strict control of component accuracy so that they can be universally assembled as a combination of ball screw support bearing set.

(a) Combined bearings

- Fig. 2 shows examples of combinations. There is "V" mark on the outside surface of the bearing to avoid misarrangement. A complete letter "V" should be formed when all bearings align correctly to form a set.
- DF combination which easily absorbs misalignment with the ball screw nut is used in general.

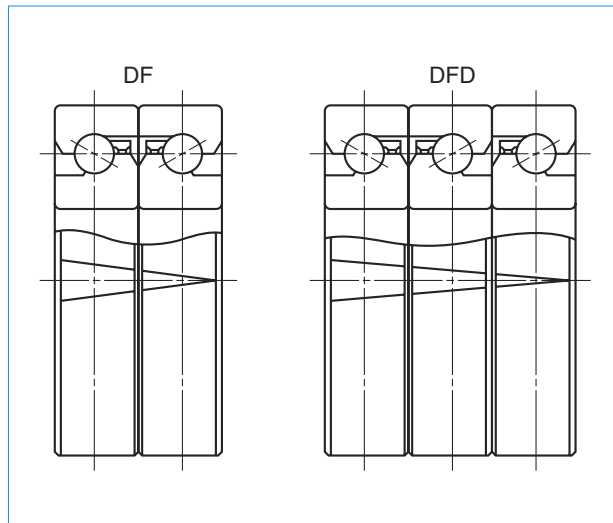

Fig. 2 Examples of combination and "V" mark

(b) Universal combination bearing (SU)

- Unlike the above case, the marks on the outside surface of bearings do not form a letter "V." The tip of the "V" on each bearing simply indicates the direction to which axial load can be applied.

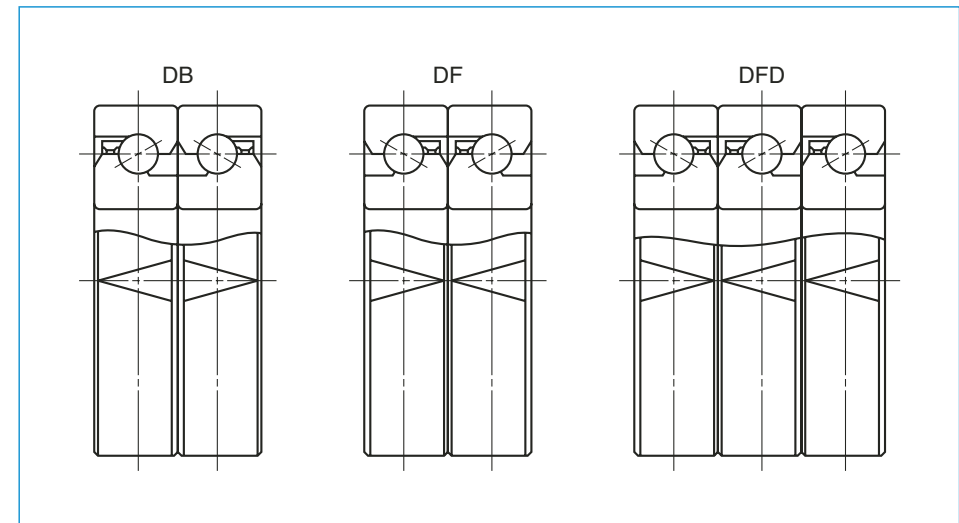

Fig. 3 Example of universal combination (SU) and "V" mark

4) Preload, rigidity, starting torque

Table 3 shows preload, rigidity (spring constant), and starting torque with grease lubrication. (Oil lubrication: Value of starting torque in the table x 1.4)
Please contact NSK for combinations other than those in the table.

5) Accuracy

(a) Accuracy grades
NSK standard PN7C, equivalent to JIS class 4 for radial ball bearings.

(b) Fitting
Recommended values for dimensional tolerances for shaft and housing bore are shown in Table 5.

Table 3 Preload, rigidity, and starting torque

Reference No.	Preload code	Duplex combination DF		
		Preload (N)	Axial rigidity (N/μm)	Starting torque (N · m)
15TAC47C	H	1 450	630	0.09
17TAC47C	H	1 450	630	0.09
20TAC47C	H	1 450	630	0.09
25TAC62C	H	2 280	850	0.15
30TAC62C	H	2 400	890	0.16
35TAC72C	H	2 750	1 030	0.18
40TAC72C	H	2 860	1 080	0.19
40TAC90C	H	3 450	1 150	0.29
45TAC75C	H	3 100	1 170	0.20
45TAC100C	H	4 440	1 340	0.40
50TAC100C	H	4 650	1 410	0.42
55TAC100C	H	4 650	1 410	0.42
55TAC120C	H	5 450	1 660	0.49
60TAC120C	H	5 450	1 660	0.49

Table 4 Tolerance: thrust angular contact ball bearing for ball screw support

Unit: μm

Nominal bore or outside diameter (mm)		Single plane mean bore dia. deviation ΔDmp		Tolerance of bore ΔDs		Single plane mean outside dia. deviation ΔDmp		Tolerance of outside diameter ΔDs		Tolerance of inner ring width ΔBs		Axial run out of inner or outer ring Sia or Sea
over	or less	upper	lower	upper	lower	upper	lower	upper	lower	upper	lower	Maximum
10	18	0	-4	0	-4	-	-	-	-	0	-120	2.5
18	30	0	-5	0	-5	-	-	-	-	0	-120	2.5
30	50	0	-6	0	-6	0	-6	0	-6	0	-120	2.5
50	80	0	-7	0	-7	0	-7	0	-7	0	-150	2.5
80	120	0	-8	0	-8	0	-8	0	-8	0	-200	2.5

Note: The tolerance of the outer ring width is the same as that of the inner ring width of the same bearing.

Triplex combination DFD			Quadruplet combination DFF		
Preload (N)	Axial rigidity (N/μm)	Starting torque (N · m)	Preload (N)	Axial rigidity (N/μm)	Starting torque (N · m)
1 970	930	0.12	2 900	1 250	0.17
1 970	930	0.12	2 900	1 250	0.17
1 970	930	0.12	2 900	1 250	0.17
3 100	1 250	0.20	4 560	1 690	0.30
3 260	1 320	0.21	4 790	1 780	0.31
3 740	1 510	0.24	5 490	2 050	0.36
3 900	1 590	0.25	5 730	2 140	0.37
4 700	1 700	0.40	6 900	2 300	0.59
4 210	1 730	0.27	6 190	2 330	0.40
6 050	1 990	0.54	8 890	2 670	0.80
6 320	2 080	0.56	9 290	2 800	0.83
6 320	2 080	0.56	9 290	2 800	0.83
7 420	2 450	0.66	10 900	3 300	0.97
7 420	2 450	0.66	10 900	3 300	0.97

Table 5 Tolerance of shaft bearing seat and housing bore

Unit: μm

Size of shaft or housing bore (mm)		Tolerance of shaft bearing seat h5		Tolerance of housing hole H6	
over	or less	upper	lower	upper	lower
10	18	0	-8	-	-
18	30	0	-9	-	-
30	50	0	-11	16	0
50	80	0	-13	19	0
80	120	0	-15	22	0

****TAC**C**

Bore 15 to 60 mm

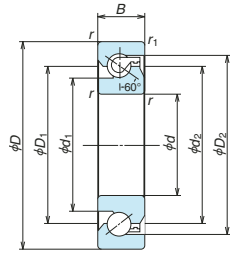

Duplex combination

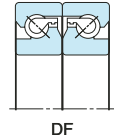

DF

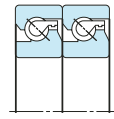

DT

Triplex combination

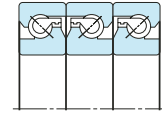

DFD

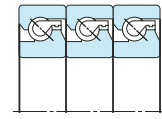

DTD

Quadruplet combination

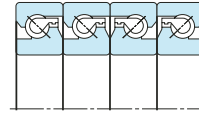

DFF

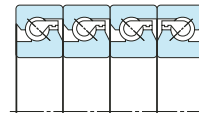

DFT

Dynamic equivalent load $P_a = XF_r + F_a$

Bearing configuration Combination code Number of rows per raceway and ball	Duplex		Triplex			Quadruplet		
	DF	DT	DFD	DTD	DFT	DFF	DFT	
$e = 2.17$	One row	Two rows	One row	Two rows	Three rows	One row	Two rows	Three rows
$F_a/F_r \leq e$	X 1.9	-	1.43	2.33	-	1.17	1.9	2.53
	Y 0.55	-	0.77	0.35	-	0.89	0.55	0.26
$F_a/F_r > e$	X 0.92	0.92	0.92	0.92	0.92	0.92	0.92	0.92
	Y 1	1	1	1	1	1	1	1

Contact seal	Non-contact seal	Boundary dimensions (mm)					Dimensions (mm)				Permissible rotational speed (min ⁻¹)		Bearing No.
		d	D	B	r Min.	r ₁ Min.	d ₁	d ₂	D ₁	D ₂	Grease lubrication	Oil lubrication	
*	*	15	47	15	1	0.6	27.2	34	34	39.6	6 900	9 200	15TAC47C
*	*	17	47	15	1	0.6	27.2	34	34	39.6	6 900	9 200	17TAC47C
*	*	20	47	15	1	0.6	27.2	34	34	39.6	6 900	9 200	20TAC47C
*	*	25	62	15	1	0.6	37	45	45	50.7	5 200	6 900	25TAC62C
*		30	62	15	1	0.6	39.5	47	47	53.2	4 900	6 400	30TAC62C
*		35	72	15	1	0.6	47	55	55	60.7	4 100	5 800	35TAC72C
*		40	72	15	1	0.6	49	57	57	62.7	4 100	5 500	40TAC72C
*		40	90	20	1	0.6	57	68	68	77.2	3 500	4 600	40TAC90C
*		45	75	15	1	0.6	54	62	62	67.7	3 700	4 900	45TAC75C
*		45	100	20	1	0.6	64	75	75	84.2	3 000	4 100	45TAC100C
*		50	100	20	1	0.6	67.5	79	79	87.7	3 000	3 900	50TAC100C
*		55	100	20	1	0.6	67.5	79	79	87.7	3 000	3 900	55TAC100C
*		55	120	20	1	0.6	82	93	93	102.2	2 500	3 500	55TAC120C
*		60	120	20	1	0.6	82	93	93	102.2	2 500	3 500	60TAC120C

Basic dynamic load rating C _a			Permissible axial load			Mass (kg)
One row sustaining load DF (N)	Two rows sustaining load DT, DFD, DFF (N)	Three row sustaining load DTD, DFT (N)	One row sustaining load DF (N)	Two rows sustaining load DT, DFD, DFF (N)	Three row sustaining load DTD, DFT (N)	
23 000	37 500	49 500	26 600	53 000	79 500	0.146
23 000	37 500	49 500	26 600	53 000	79 500	0.140
23 000	37 500	49 500	26 600	53 000	79 500	0.135
29 900	48 500	64 500	40 500	81 500	122 000	0.252
30 500	50 000	66 000	43 000	86 000	129 000	0.224
32 500	53 000	70 500	50 000	100 000	150 000	0.310
33 500	54 000	72 000	52 000	10 400	157 000	0.275
62 000	101 000	134 000	89 500	179 000	269 000	0.674
34 500	56 000	74 500	57 000	114 000	170 000	0.270
64 500	105 000	140 000	99 000	198 000	298 000	0.842
66 000	107 000	142 000	104 000	208 000	310 000	0.778
66 000	107 000	142 000	104 000	208 000	310 000	0.714
70 500	115 000	153 000	123 000	246 000	370 000	1.23
70 500	115 000	153 000	123 000	246 000	370 000	1.16

- Note:** 1. * Asterisk indicates bearing with contact seal or non-contact seal.
 2. Permissible rotation speed is the value with H preload applied. The value is not influenced by bearing layout.
 3. Numerical value indicates starting torque with grease lubrication. In the case of oil lubrication, the value in the above table should be multiplied by 1.4.
 4. Allowable axial load is 0.7 times of load limit.

(7) Ball Screw Support Bearings

BSBD Series

The BSBD series are ball screw support bearings unit that can accurately and quickly position a work piece or a main spindle unit.



Features

The bearings are double row, angular contact ball bearings, with a 60° contact angle and a single outer ring. These have the same specs as TAC bearings, the best specs for ball screw support bearing for machine tools. High-performance grease and contact rubber seal are included as standard.

● **BSN series**

A double row, angular contact thrust ball bearing in a back-to-back (DB) arrangement with a single outer ring. Already filled with high-performance grease, operation is easy. Lubrication holes allow for relubrication as required. The contact type seal has excellent seal performance, while minimizing effects on friction loss and heat generation. Axial clearance has been adjusted for the best preload after installing to shaft.

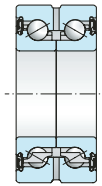

● **BSF series**

The BSF series bearings have outer ring bolt holes in addition to the BSN series bearings. Direct mounting on housing side is easy. A lubrication hole on each OD surface and on the side of the bearings, allows relubrication as required. When the holes are not used, plugs prevent foreign matter from entering. In addition, an extraction groove on OD surface of outer ring enhances bearing removal.

Note: Bearing with seal and plug are included. Mounting bolts are not included.

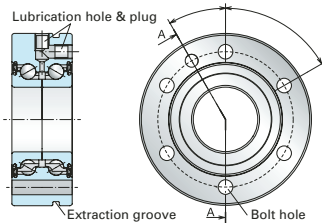

BSN series Single product

Unit: mm

Bearing Numbers	Boundary Dimensions (mm)				Reference Dimensions (mm)		Contact Angle (°)	Basic Load Rating (kN)		Limiting ¹⁾ Axial Load (kN)	Preload (N)	Axial Rigidity (N/μm)	Mass (kg)	Allowable rotating speed (min ⁻¹) Greased	Starting torque (N·m) H ²⁾	Tightening Torque (N·m) (Ref.)
	d	D	B	r (min)	d _i	D ₁		C _r (Dynamic)	C _{0a} (Static)							
BSN1747	17	47	25	0.6	28.1	37.7	60	19.3	29.7	21.2	880	450	0.23	6 700	0.05	19
BSN2052	20	52	28	0.6	32.6	43	60	25.1	41.0	29.3	1 885	650	0.31	5 800	0.13	25
BSN2557	25	57	28	0.6	37.6	48	60	27.0	48.0	34.0	2 245	750	0.36	5 100	0.16	35
BSN3062	30	62	28	0.6	42.6	53	60	28.6	55.5	38.5	2 625	850	0.40	4 500	0.19	45
BSN3072	30	72	38	0.6	49.1	64.4	60	57.5	94.0	66.5	4 855	950	0.74	3 900	0.59	80
BSN3572	35	72	34	0.6	53.1	62.2	60	40.0	77.5	52.0	2 630	900	0.66	3 800	0.21	50
BSN4075	40	75	34	0.6	56.2	68.1	60	42.0	88.0	58.5	3 065	1 000	0.65	3 500	0.24	65
BSN4090	40	90	46	0.6	63.2	80	60	75.0	135	91.0	7 220	1 200	1.38	3 100	1.02	155
BSN5090	50	90	34	0.6	70.2	82.1	60	45.5	110	71.5	4 020	1 250	0.93	2 800	0.33	110
BSN50110	50	110	54	0.6	78.2	97.4	60	110	219	149	7 435	1 400	2.46	2 500	1.06	200
BSN60110	60	110	45	0.6	83.2	99.2	60	82.5	187	126	4 780	1 300	1.82	2 400	0.50	155

Notes: 1. Allowable axial load is 0.7 times of load limit.
2. Starting torque indicates torque due to the preload of the bearing. It does not include seal torque.

BSBD Series: Nomenclature

Example: **BS F 30 80 DDU H P2B DT**

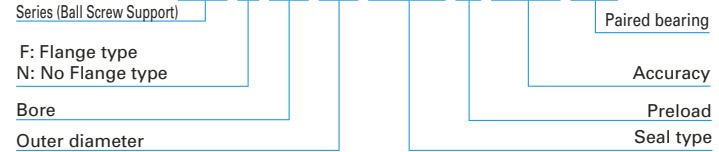

Note: Accuracy P2B: Special class for this series. It indicates the following.
Rotation accuracy: ISO class 2
Other: Special

● **Seal**

Contact rubber seals are on both sides. Triple lip structure achieves high grease sealing and dust-proof performance.

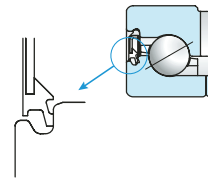

● **Matched DT pairs**

A paired product for large external load or when high rigidity and long life are required. Can be used in four rows with no effects on preload individual bearings as distance between mating surfaces has been adjusted.

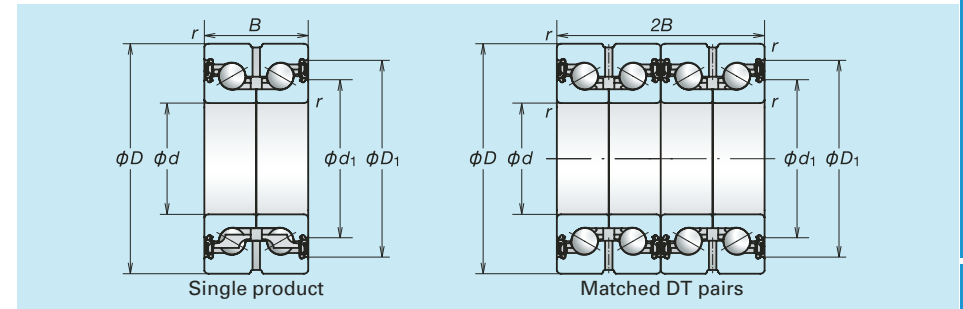
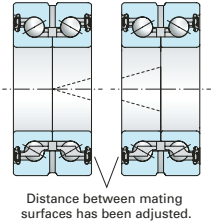

BSN series matched DT pairs

Bearing Numbers	Boundary Dimensions (mm)				Reference Dimensions (mm)		Contact Angle (°)	Basic Load Rating (kN)		Limiting ¹⁾ Axial Load (kN)	Axial Rigidity (N/μm)	Mass (kg)	Allowable rotating speed (min ⁻¹) Greased	Starting torque (N·m) H ²⁾	Tightening Torque (N·m) (Ref.)
	d	D	2B	r (min)	d _i	D ₁		C _r (Dynamic)	C _{0a} (Static)						
BSN1747-DT	17	47	50	0.6	28.1	37.7	60	31.5	59.5	42.5	790	0.46	6 700	0.10	19
BSN2052-DT	20	52	56	0.6	32.6	43	60	41.0	82.0	58.5	1 180	0.62	5 800	0.26	25
BSN2557-DT	25	57	56	0.6	37.6	48	60	44.0	96.0	68.0	1 370	0.71	5 100	0.32	35
BSN3062-DT	30	62	56	0.6	42.6	53	60	46.5	111	77.0	1 580	0.80	4 500	0.37	45
BSN3072-DT	30	72	76	0.6	49.1	64.4	60	93.5	188	133	1 800	1.47	3 900	1.17	80
BSN3572-DT	35	72	68	0.6	53.1	62.2	60	64.5	155	104	1 630	1.32	3 800	0.41	50
BSN4075-DT	40	75	68	0.6	56.2	68.1	60	68.5	176	117	1 850	1.30	3 500	0.49	65
BSN4090-DT	40	90	92	0.6	63.2	80	60	122	269	182	2 300	2.76	3 100	2.03	155
BSN5090-DT	50	90	68	0.6	70.2	82.1	60	74.0	220	143	2 330	1.86	2 800	0.66	110
BSN50110-DT	50	110	108	0.6	78.2	97.4	60	179	440	299	2 690	4.92	2 500	2.11	200

BSBD Series

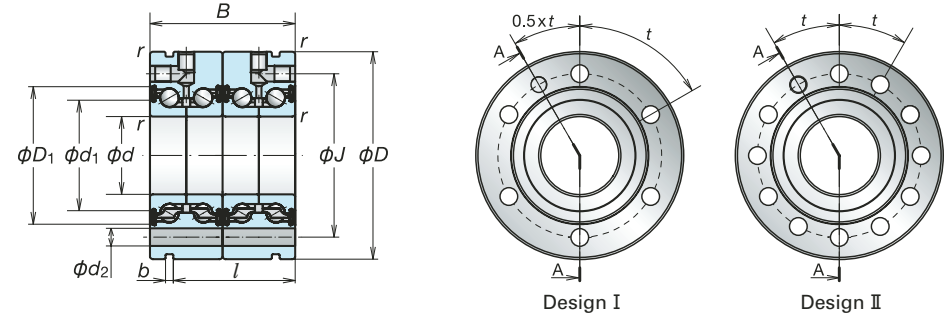
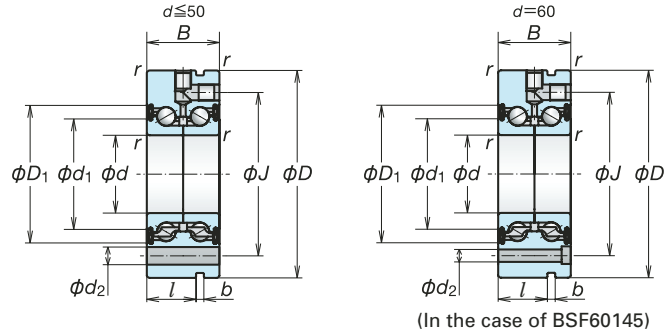

BSF series Single product

Bearing Numbers	Boundary Dimensions (mm)				Basic Load Rating (kN)		Limiting ⁽¹⁾ Axial Load (kN)	Axial Rigidity (N/μm)	Mass (kg)	Allowable rotating speed (min ⁻¹) Grease Lubrication
	d	D	B	r (min)	C _o (Dynamic)	C _{os} (Static)				
BSF1762	17	62	25	0.6	19.3	29.7	21.2	450	0.46	6 700
BSF2068	20	68	28	0.6	25.1	41.0	29.3	650	0.61	5 800
BSF2575	25	75	28	0.6	27.0	48.0	34.0	750	0.73	5 100
BSF3080	30	80	28	0.6	28.6	55.5	38.5	850	0.79	4 500
BSF30100	30	100	38	0.6	57.5	94	66.5	950	1.71	3 900
BSF3590	35	90	34	0.6	40.0	77.5	52.0	900	1.20	3 800
BSF40100	40	100	34	0.6	42.0	88.0	58.5	1 000	1.49	3 500
BSF40115	40	115	46	0.6	75.0	135	91.0	1 200	2.56	3 100
BSF50115	50	115	34	0.6	45.5	110	71.5	1 250	1.89	2 800
BSF50140	50	140	54	0.6	110	219	149	1 400	4.46	2 500
BSF60145	60	145	45	0.6	82.5	187	126	1 300	4.06	2 400

Reference Dimensions (mm)							Design	Fixing Screws		Preload (N)	Starting torque ⁽²⁾ (N·m) H	Tightening Torque (N·m) (Ref.)
d	D ₁	J	d ₂	l	b	t		Size	Quantity			
28.1	37.7	48	6.8	17	3	3 × 120°	I	M6	3	890	0.05	19
32.6	43	53	6.8	19	3	4 × 90°	I	M6	4	1 885	0.13	25
37.6	48	58	6.8	19	3	4 × 90°	I	M6	4	2 245	0.16	35
42.6	53	63	6.8	19	3	6 × 60°	I	M6	6	2 625	0.19	45
49.1	64.4	80	8.8	30	3	8 × 45°	I	M8	8	4 855	0.59	80
53.1	62.2	75	8.8	25	3	4 × 90°	I	M8	4	2 630	0.21	50
55.1	67.2	80	8.8	25	3	4 × 90°	I	M8	4	3 065	0.24	65
63.1	80.1	94	8.8	36	3	12 × 30°	I	M8	12	7 220	1.02	155
70.1	82.2	94	8.8	25	3	6 × 60°	I	M8	6	4 020	0.33	110
78.1	97.5	113	11	45	3	12 × 30°	I	M10	12	7 435	1.06	200
83.1	99.3	120	8.8	35	3	8 × 45°	I	M8	8	4 780	0.50	155

BSF series matched pairs

Bearing Numbers	Boundary Dimensions (mm)				Basic Load Rating (kN)		Limiting ⁽¹⁾ Axial Load (kN)	Axial Rigidity (N/μm)	Mass (kg)	Allowable rotating speed (min ⁻¹) Grease Lubrication
	d	D	B	r (min)	C _o (Dynamic)	C _{os} (Static)				
BSF1762-DT	17	62	50	0.6	31.5	59.5	42.5	790	0.890	6 700
BSF2068-DT	20	68	56	0.6	41.0	82.0	58.5	1 180	1.17	5 800
BSF2575-DT	25	75	56	0.6	44.0	96.0	68.0	1 370	1.46	5 100
BSF3080-DT	30	80	56	0.6	46.5	111	77.0	1 580	1.58	4 500
BSF30100-DT	30	100	76	0.6	93.5	188	133	1 800	3.41	3 900
BSF3590-DT	35	90	68	0.6	64.5	155	104	1 630	2.30	3 800
BSF40100-DT	40	100	68	0.6	68.5	176	117	1 850	2.88	3 500
BSF40115-DT	40	115	92	0.6	122	269	182	2 300	5.12	3 100
BSF50115-DT	50	115	68	0.6	74.0	220	143	2 330	3.78	2 800
BSF50140-DT	50	140	108	0.6	179	440	299	2 690	8.92	2 500

Reference Dimensions (mm)							Design	Fixing Screws		Starting torque ⁽²⁾ (N·m) H	Tightening Torque (N·m) (Ref.)
d	D ₁	J	d ₂	l	b	t		Size	Quantity		
28.1	37.7	48	6.8	42	3	6 × 60°	II	M6	5	0.10	19
32.6	43	53	6.8	47	3	8 × 45°	II	M6	7	0.26	25
37.6	48	58	6.8	47	3	8 × 45°	II	M6	7	0.32	35
42.6	53	63	6.8	47	3	12 × 30°	II	M6	11	0.37	45
49.1	64.4	80	8.8	68	3	8 × 45°	I	M8	8	1.17	80
53.1	62.2	75	8.8	59	3	8 × 45°	II	M8	7	0.41	50
55.1	67.2	80	8.8	59	3	8 × 45°	II	M8	7	0.49	65
63.1	80.1	94	8.8	82	3	12 × 30°	I	M8	12	2.03	155
70.1	82.2	94	8.8	59	3	12 × 30°	II	M8	11	0.66	110
78.1	97.5	113	11	99	3	12 × 30°	I	M10	12	2.11	200

- Notes: 1. Allowable axial load is 0.7 times of load limit.
This is the limiting load of the bearing. It does not include strength of the mounting bolt.
2. Starting torque indicates torque due to the preload of the bearing. It does not include seal torque.